

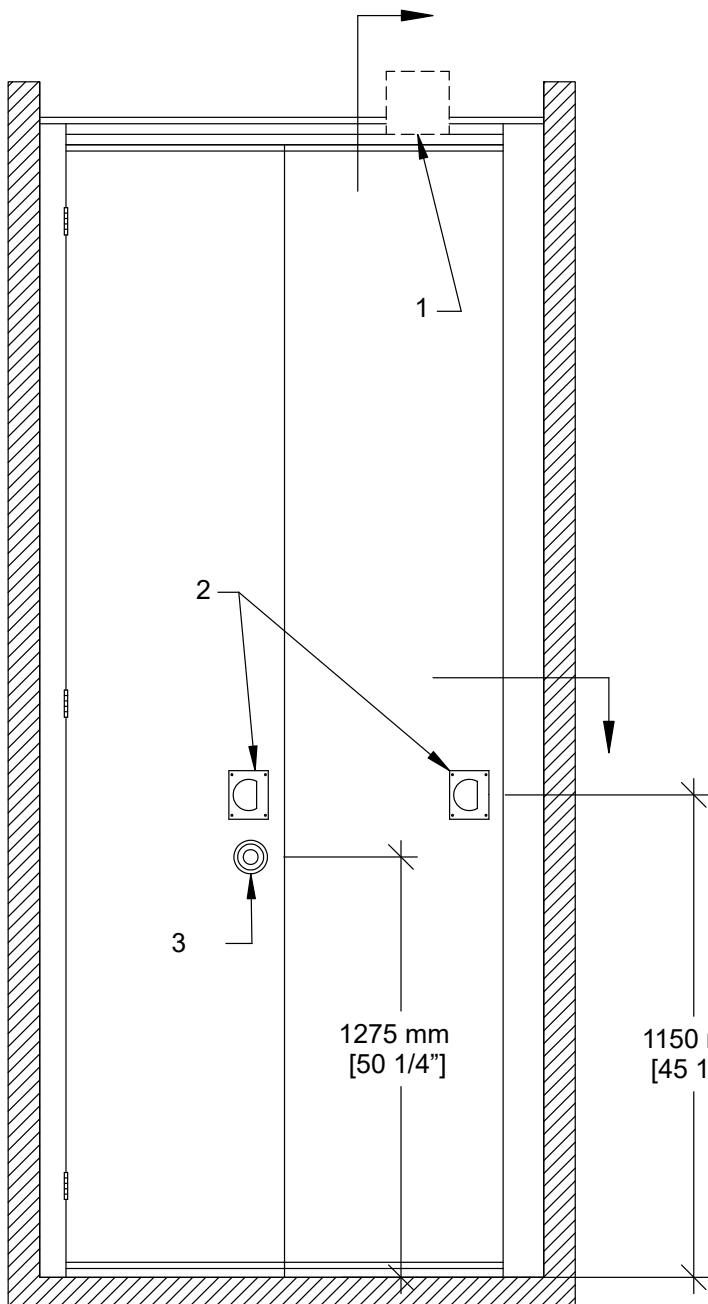

# MODERCO

Excel 700 Series

## Technical Data Sheet Excel 700 PN-72B Pocket Doors



### **PN-72B Non-acoustical Pocket Door**

- 2 bi-folding sections
- Same basic construction as movable partition panels
- Same surface finish as movable partition / optional custom finish / unfinished
- Same frame finish as movable partition / optional custom finish
- Top and bottom sliding bolts
- Optional lock for top and bottom sliding bolts
- Low profile steel hinges

- 1- Track
- 2- Flush pulls
- 3- Top and bottom sliding bolt activator

**Vertical Section**

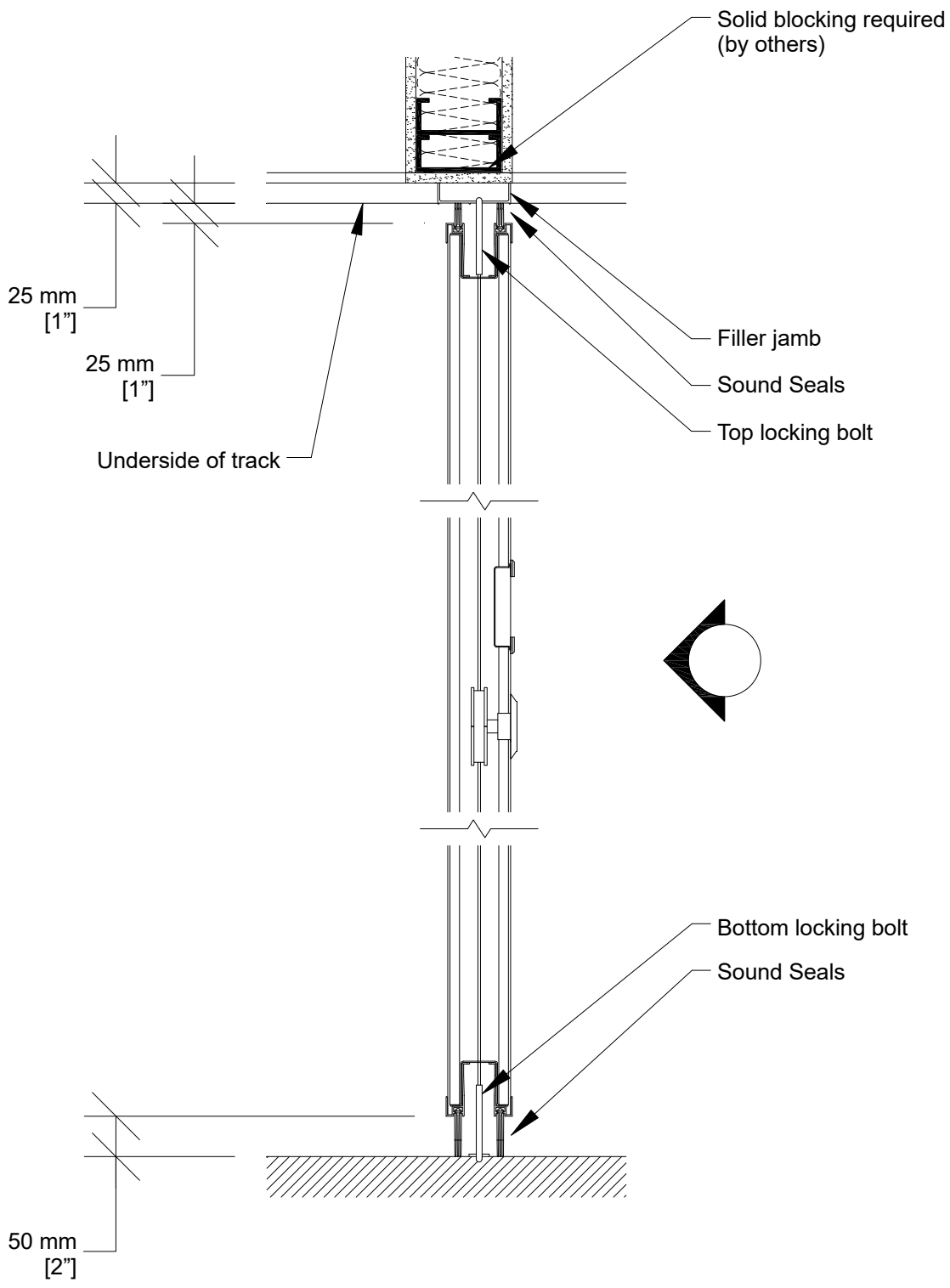

### Horizontal Section

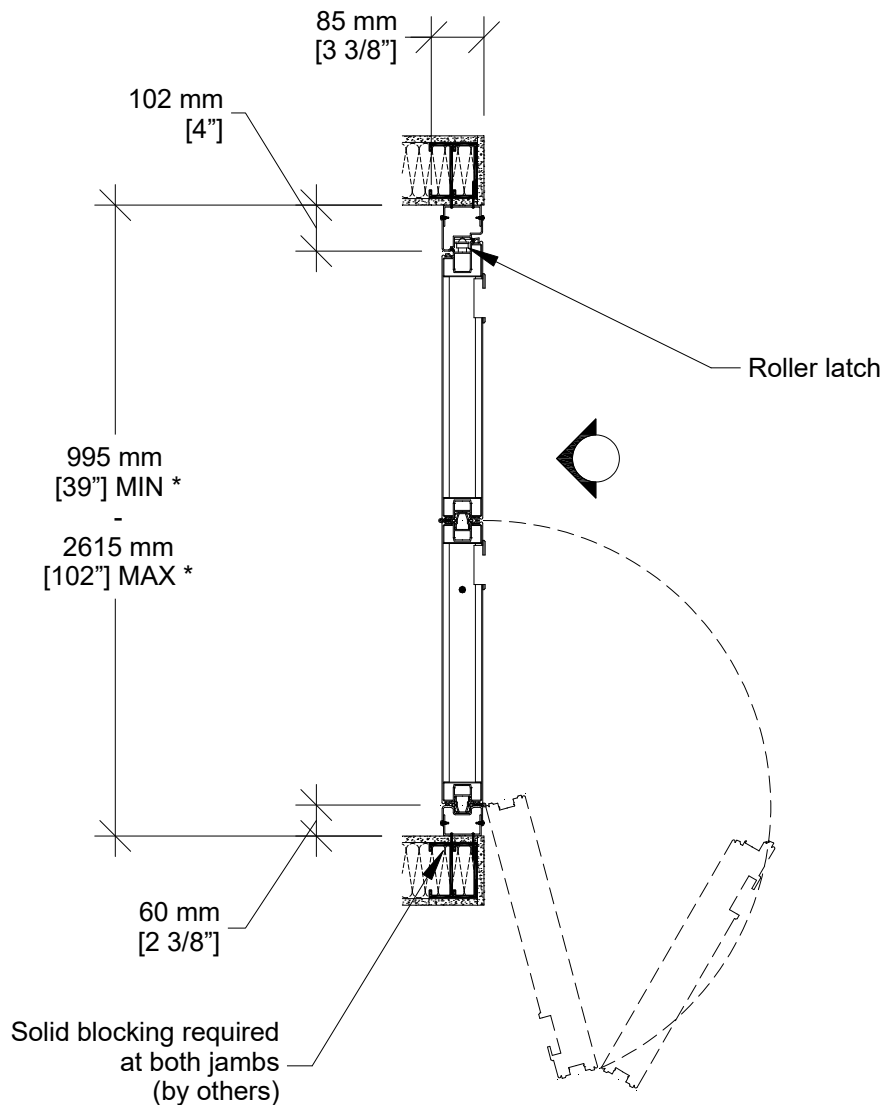

\* Min/Max dimensions are fabrication limits and do not account for job-specific conditions.

Please consult shop drawings or local Moderco distributor prior to sizing pockets.