

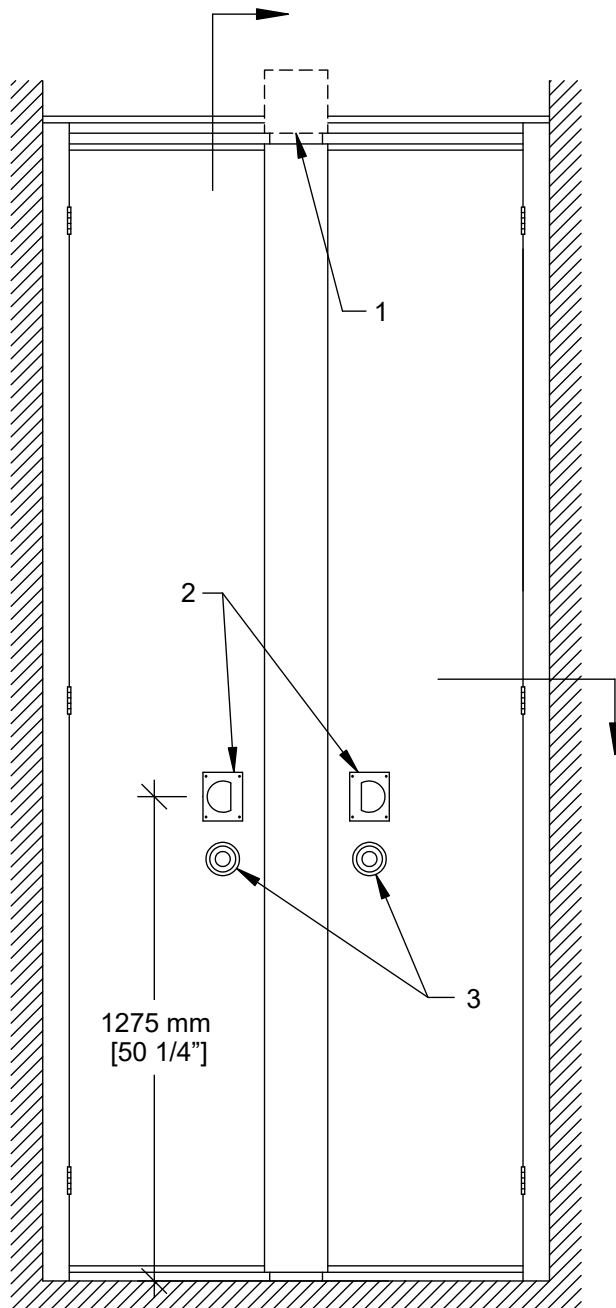

**MODERCO**

Excel 700 Series

## Technical Data Sheet Excel 700 PN-73 Pocket Door



### **PN-73 Non-acoustical Pocket Door**

- 2 independent sections and 1 hinged center flap
- Same basic construction as movable partition panels
- Same surface finish as movable partition / optional custom finish / unfinished
- Same frame finish as movable partition / optional custom finish
- Low profile steel hinges
- Top and bottom sliding bolts
- Optional lock for top and bottom sliding bolts

- 1- Track
- 2- Flush pulls
- 3- Top and bottom sliding bolt activator

### Vertical Section

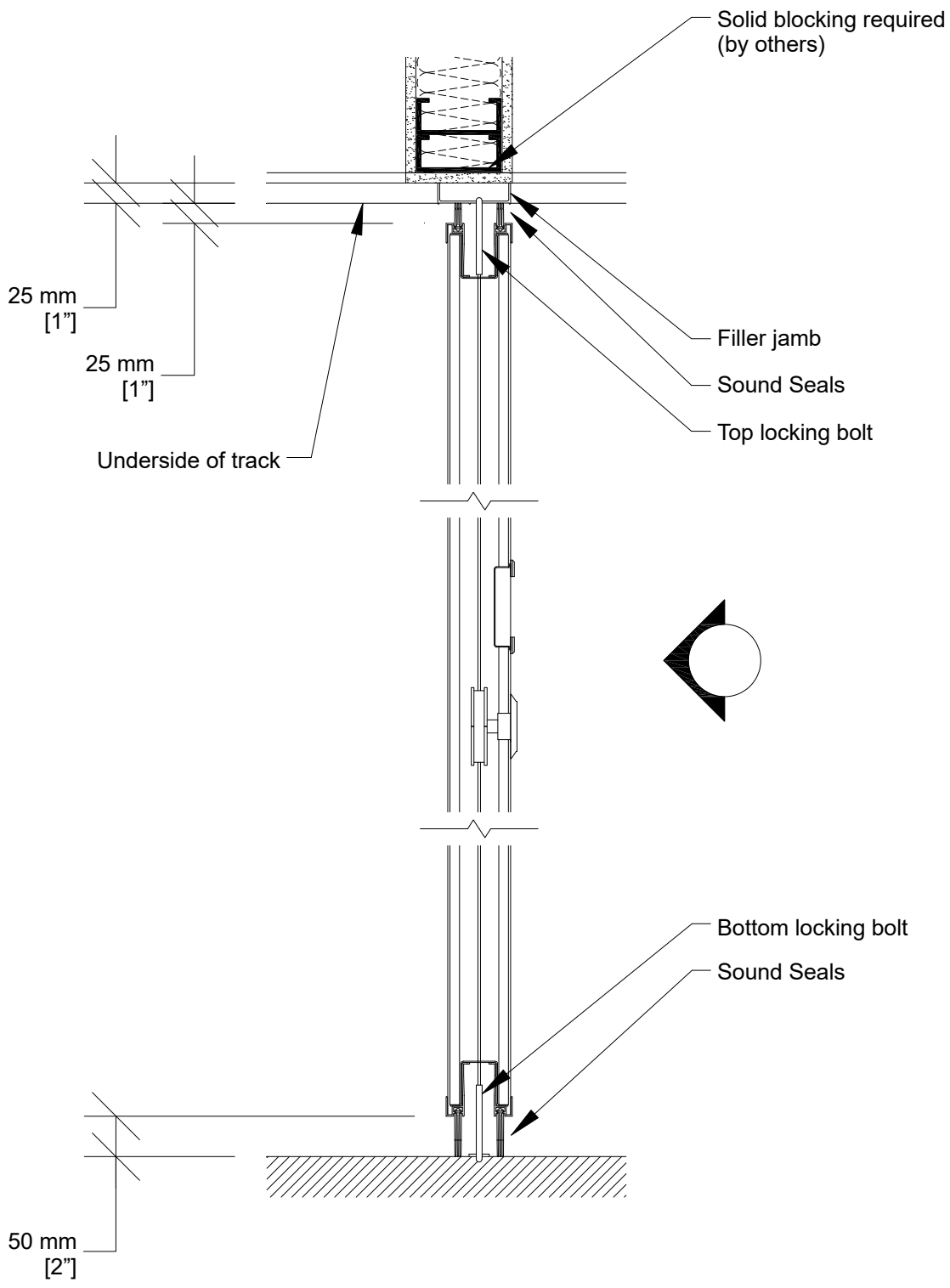

### Horizontal Section

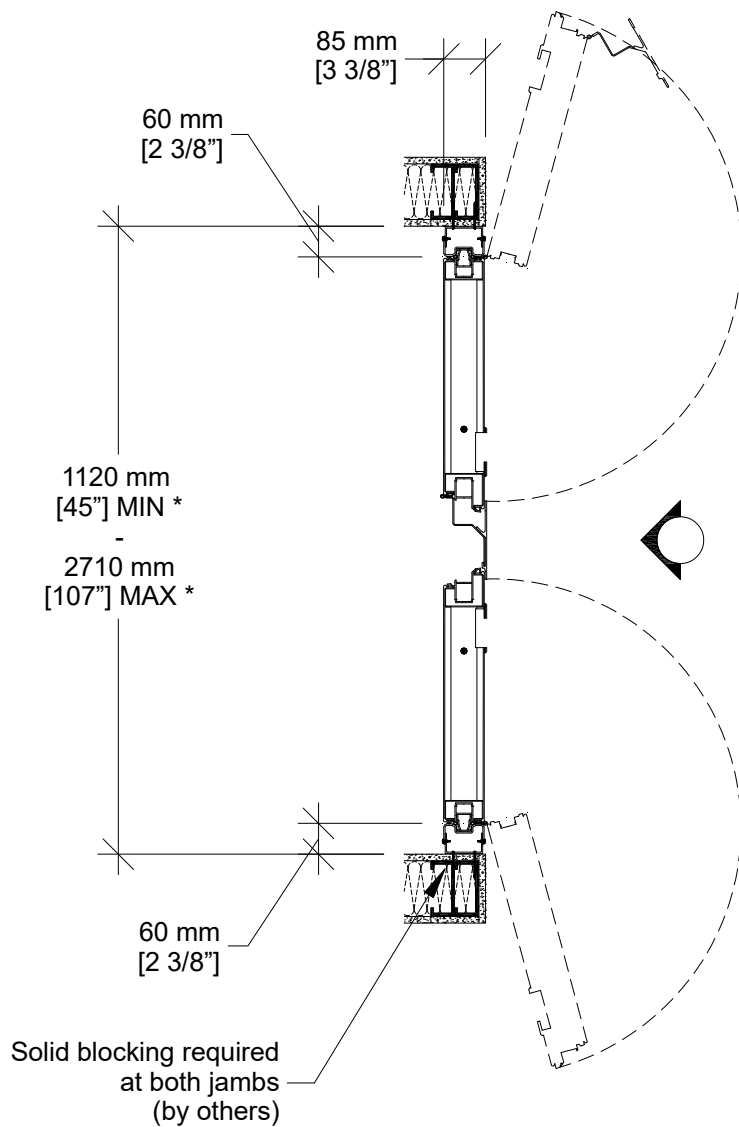

\* Min/Max dimensions are fabrication limits and do not account for job-specific conditions.

Please consult shop drawings or local Moderco distributor prior to sizing pockets.